

Bluetone Melissa

Power amp and power supply schematics

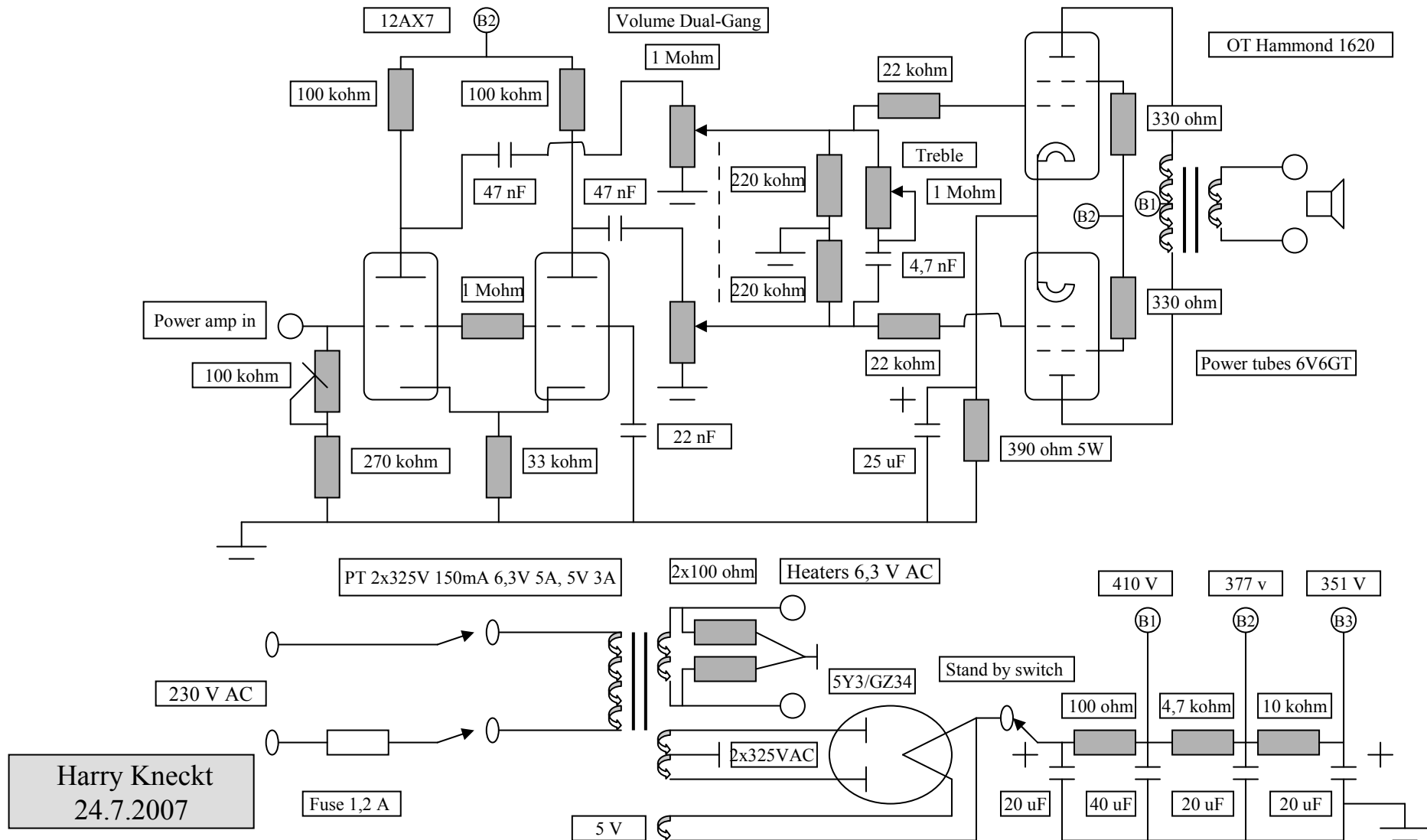

Harry Knecht
24.7.2007

Bluetone Melissa

Voltage chart

V1(12AX7)

1= 142 V

3= 1,1 V

7= 43,6/0,9 V

6= 196 V

8= 45,1 V

V2(12AX7)

1= 251 V

2= 77,5/1,2 V

3= 80,9 V

6= 255 V

7= 65,1 V

8= 80,9 V

V3(6V6GT)

3= 408 V

4= 376 V

8= 27,1 V

V4(6V6GT)

3= 408 V

4= 376 V

8= 27,1 V

Preamp 100 kohm trimmers are used
to adjust bias to V1/7 and V2/2

Harry Knecht

24.7.2007